



MAXIMIZING ACCURACY
in
MICROINCH MEASUREMENT

Stephen R. Noonan

PRATT & WHITNEY
MEASUREMENT SYSTEMS, INC.

www.prattandwhitney.com

MAXIMIZING ACCURACY in MICROINCH MEASUREMENT

Stephen R. Noonan

*Pratt & Whitney Measurement Systems, Inc.
Bloomfield, CT*

Abstract

Millionths of an inch (0.025 micron) measurement requires special methods and equipment. This paper will discuss considerations and practices we have found effective for maximizing accuracy in microinch measurement. Topics covered will include temperature, contamination, penetration, alignment, vibration, wear, looseness, the operator, and equipment.

Introduction

There are a number of factors that affect microinch measurement accuracy. The critical factors are: temperature, contamination, contact point penetration, looseness, alignment, vibration, wear, accuracy of the masters, the instrument operator, and the instrument itself. Of all the factors listed, temperature causes the largest variation in microinch measurement.

Temperature

Temperature fluctuations create a problem in measurement because they cause instrument readings to drift. For example, a 1" steel block will grow 6.5 microinches with a 1 °F temperature increase. Likewise, a 100mm steel block will grow 1.2 microns per °C. Therefore, calibrating gage blocks requires the same care as calibrating thermometers.

The problem is further complicated by the fact that specimens of different sizes and shapes change temperature at different rates. A 1 inch (25mm) gage block changes temperature faster than a 4 inch (100mm) gage block. Additionally, one should note that constant temperature rooms are not constant, that in fact they all vary to some degree. As a result parts and equipment in the room are growing and shrinking at various rates dependent on their material, size, and shape.

To minimize thermal effects, one should take the following actions.

- Measure at 68 °F (20 °C)
- Control room temperature as tightly as possible (variation of less than 0.25 °F is desirable)
- Avoid windows
- Use a soak plate
- Keep parts and masters close together
- Allow enough "soak time" for parts to acclimate (2-24 hours, depending on part size)
- Measure parts quickly
- Sandwich readings (master, part1, part2 . . . , master)
- Use software correction
- Use gloves or tongs to handle specimens
- Shield equipment
- Master using the same material as the measured parts

Contamination

In microinch measurement contaminant can be defined as anything larger than a millionth of an inch. Contamination becomes a factor because it causes non-repeatability. If 1 microinch was 1 inch, hair thickness would be about 250 feet (80 meters), bacteria would be the size of dinosaurs, and the relief between anvil serrations would resemble the Grand Canyon.

To minimize contamination:

- Clean parts with alcohol and a lint free cloth
- Use point contact geometry (ruby balls or diamond contacts with a radius yield favorable results)
- Slide parts between contacts before measuring
- Make sure parts are free of rust or stains
- Use serrated anvils
- Use a lens cleaning brush on the part
- Use air filters in the ventilation system
- Wet mop the floor instead of sweeping or vacuuming

Penetration

Let's suppose you were faced with the task of measuring foam thickness using a micrometer. It might be difficult to get good repeat readings on the foam (especially if different operators, applying varying force, take the readings.) However, if the operators used a master of the same stiffness as the one they wish to measure and insured the measuring force was constant, they would improve their chances of getting accurate and repeatable readings.

While the properties of gage blocks and foam are quite different, this example clearly demonstrates the relation between gaging force (operator force), elasticity (foam stiffness), and penetration (foam compression). These factors impact every measurement.

To minimize penetration effects:

- Master using the same material you are measuring
- Use a master that has the same shape as the part you are measuring
- Measure with the same gaging force used for your master

Alignment

When measuring the distance between two parallel surfaces (i.e. gage blocks) the minimum distance between surfaces is along a line perpendicular to the parallel surfaces (the shortest path across is a straight across). A tilted part will cause cosine error. To estimate cosine error:

$$E \approx a^2 / 2$$

Where: a = angle of tilt (rad, in/in, or mm/mm)

E = cosine error (in/in, or mm/mm)

For example, if a part is tilted 0.001 in/in (mm/mm) then the measurement error will be 0.0000005 in/in (mm/mm). If the part is 4 in (0.1 m) long then the error would be 2 microinches (0.05 microns).

To ensure that parts are properly aligned:

- Align part reference figures
- Rotate the part while searching for a minimum reading

Looseness

Looseness can be described as a minute rocking between two surfaces. It causes non-repeatability and is caused by loose mechanical connections.

To detect and correct looseness:

- Locate looseness by pressing near connections while observing the readout
- Tighten loose connections
- Check equipment fixturing
- Check contact surfaces for damage or wear

Vibration

Vibration causes readings to fluctuate much like a needle on a seismograph. Measuring to a millionth in the presence of vibration is analogous to measuring to an inch during an earthquake.

To minimize vibration effects:

- Reduce or eliminate the source of vibration
- Change the instrument location
- Put the instrument on a granite block
- Put cork, felt, or rubber pads under the gage or granite
- Use a vibration isolation table

Wear

Wear causes non-repeatable or inaccurate readings. The wear elements of your instrument and masters should be checked periodically. The primary wear areas are contact surfaces. Contact surfaces should be renewed or replaced as required.

To minimize wear problems:

- Keep contact surfaces clean
- Use hard contact surfaces (diamond, ruby, carbide)
- Use light gaging forces
- Examine contact points under a microscope
- Check micrometer wear with a precision ball

Operator

Ideally, taking a millionth measurement should be no harder than placing a cup in a dishwasher. In reality, high accuracy measurements require knowledge and skill.

To improve operator effectiveness:

- Understand factors that may limit measurement accuracy
- Read user's manuals and understand instrument operation
- Test skills and knowledge periodically
- Attend seminars (NCSL, NIST, ...)

Equipment

Being sensitive to the factors discussed thus far will go a long way toward helping to maximize the accuracy of your measurements. However it will not guarantee results. Microinch measurement also depends on using the right equipment; equipment designed to minimize those influencing factors described above.

We have found that equipment used for measuring to a microinch (refer to Figures 1A and 1B) should have the following features: (Features listed below correspond with letters in Figure 1A and 1B.)

- A) A high accuracy scale (we prefer a laser interferometer)
- B) The scale in line with measurement axis (Zero Abbe Offset)
- °C) Stable materials (zerodur, composites, invar, ceramic)
- D) Accurate low friction slides (air bearings are ideally suited for this application)
- E) A precision force system
- °F) Light gaging force
- G) Reduced area contact geometry (spheres are good)
- H) Hard contact materials (diamond, ruby, or carbide)
- I) Replaceable or renewable contact surfaces
- J) A method for checking part alignment
- K) Remote control (minimize operator influence)
- L) Modular subsystems (for thermal and mechanical isolation and serviceability)

Some other features are also desirable:

- English/Metric operation
- Wide direct reading range
- Simple calibration procedure
- Ability to measure a wide variety of parts
- Simple and expandable range of fixturing
- Vibration filtering
- Printed output
- Computer compatibility
- Statistical functions

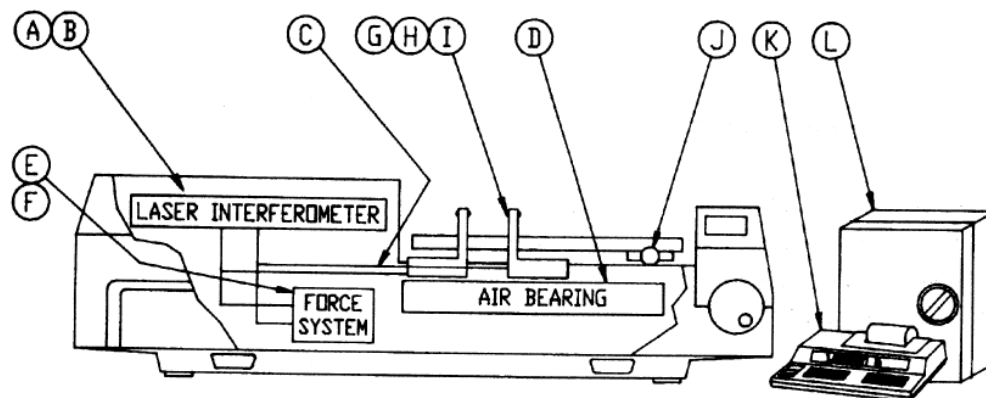

Figure 1A Horizontal Measurement System

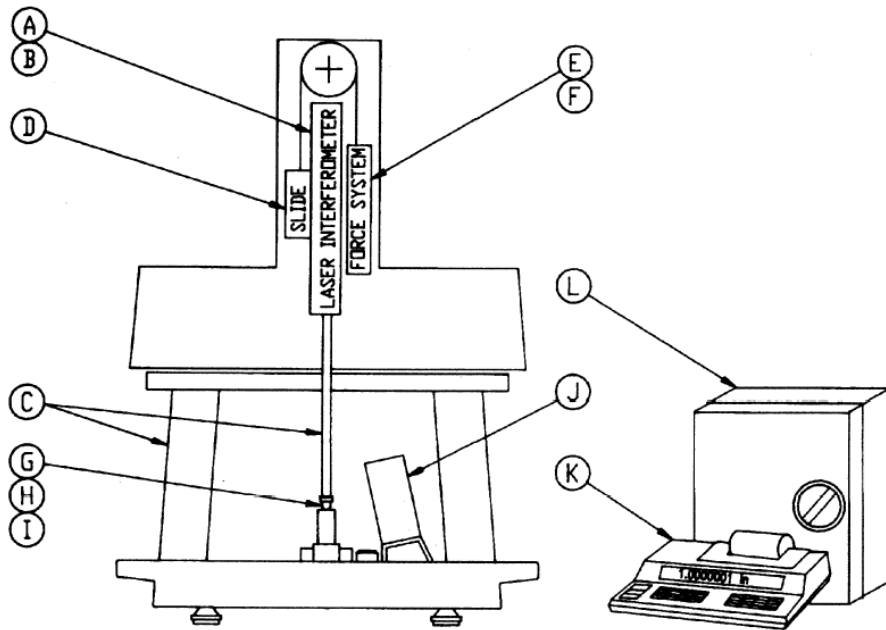

Figure 1B Vertical Measurement System

Summary

Factors that affect microinch measurement accuracy can be segregated into three categories (Figure 2). They are environment (temperature, contamination, and vibration), operation (operator technique, part presentation, and part alignment), and equipment (looseness, part alignment, contact point penetration, wear, and accuracy of the masters).

Of all the factors discussed, we have found temperature variation to have the most compromising effect on our pursuit of accurate microinch measurement. This fact underscores the importance this and other presented environmental considerations play in measurement.

Pairing a skilled operator who is sensitive to the influencing factors in measurement, with an instrument containing features that mitigate the impact of those influencing factors, represents a pragmatic approach to maximizing accuracy in microinch measurement.

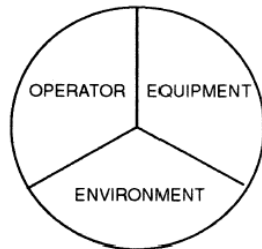

FIGURE 2 Factors Affecting Millionths Measurement

References

1. Kennedy, Clifford W., "Inspection and Gaging", Sixth Edition, Industrial Press Inc., 1987, pp. 526 through 574.
2. Cox, Hilliard, "Searching for Zero", American Measuring Tool Manufacturers Association, 1991, pp. 4 through 6.